



SY50

Hydraulic Excavator



KEY FEATURES

- Extra reinforcement of major structural members and large multi-stage air and fuel filtration make the machine more stable and reliable
- The tier 4 final power plant, advanced SLSS hydraulic system, optimal power control and work mode selection improve speed and power while reducing fuel consumption
- Zero tail swing radius and independent boom swing allow operation in extremely confined spaces. This allows operation in locations that were previously inaccessible.
- Easily accessible service points and a detachable radiator screen are among the features that make scheduled maintenance more convenient

Total Weight

5,400 Kg - 11,905 lb

Rated Power

31.2 kW @ 2,400 rpm -
42 hp @ 2,400 rpm

Bucket Digging Force

32.5 kN - 7,306 lb

SY50 Dimensions & Specifications

OVERALL DIMENSIONS

	Standard	Metric
A Transport Length	17' 8"	5390 mm
B Transport Width	6' 5"	1960 mm
C Transport Height	8' 8"	2630 mm
D Upper Frame Width	5' 9"	1760 mm
E Cab Height	1' 1"	340 mm
F Standard Track Width	1' 4"	400 mm
G Track Gauge	5' 1"	1560 mm
H Min Ground Clearance	1' 0"	325 mm
I Tail Swing Radius	3' 3"	980 mm
J Track Ground Length	6' 6"	1990 mm
K Track Length	8' 3"	2510 mm

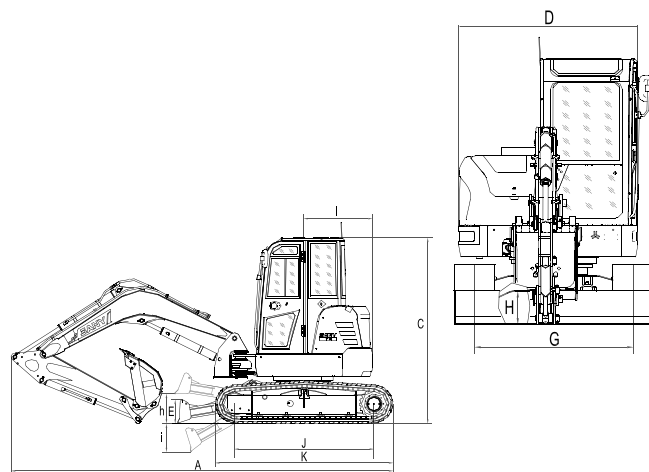

WORKING RANGE

	Standard	Metric
a Maximum Digging Height	17' 11"	5450 mm
b Maximum Dumping Height	12' 6"	3805 mm
c Maximum Digging Depth	11' 3"	3420 mm
d Maximum Vertical Wall Digging Depth	8' 1"	2460 mm
e Maximum Digging Reach	19' 3"	5880 mm
f Minimum Swing Radius	8' 3"	2520 mm
g Maximum Height at Minimum Swing Radius	13' 8"	4155 mm

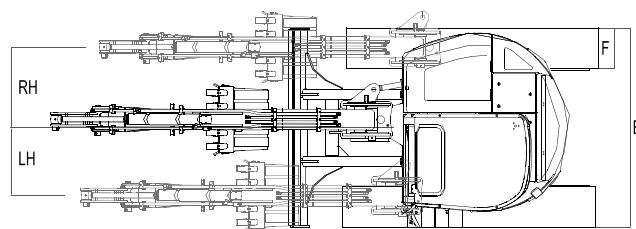

MACHINE PARAMETERS

Operating Weight	11,905 lb - 5,400 Kg
Engine Type	Yanmar
Engine Max Power (Gross)	39 hp/29.1 kW @ 2400 rpm
Engine Max Torque	133.3 ft-lbs/144.9 Nm @ 1500 rpm
Engine Displacement	133.8 in ³ - 2.191
Main Pump Flow	29 gal/110 lpm
Swing Speed	10 rpm
Travel Speed	2.5/1.5 mph 4.1/2.4 kph
Tractive Effort	9,150 lbf - 40.7 kN
Max Arm Digging Force (SAE)	5,150 lbf - 22.9 kN
Number of Upper Rollers	2
Number of Lower Rollers	4
Fuel Tank Capacity	20.6 gal - 78 L
Hydraulic Tank Capacity	13.7 gal - 52 L
Cooling System Capacity	1.1 gal - 4.2 L
Engine Oil Capacity	2.0 gal - 7.4 L
Ground Pressure	4.5 psi - 31.6 kPa

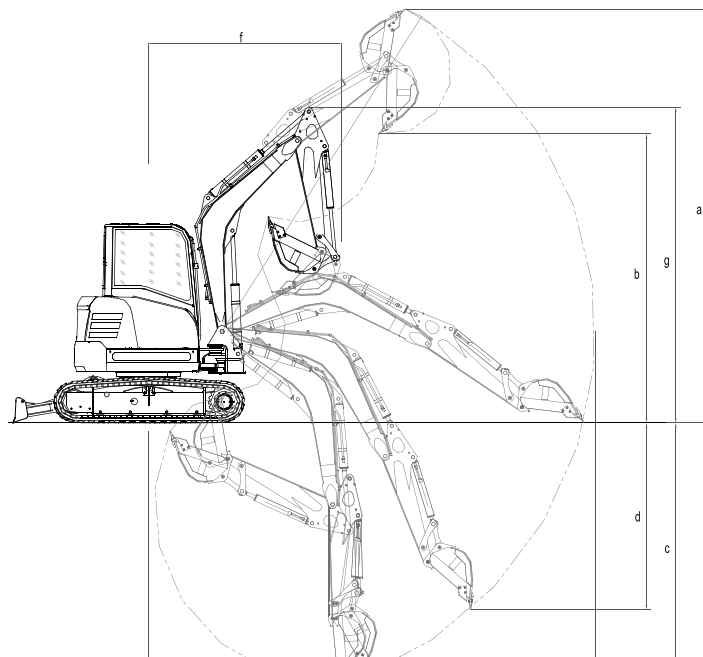

SANY America Inc.

318 Cooper Circle | Peachtree City, GA 30269
T: 678-251-2810 | F: 770-632-7820

www.sanyamerica.com

